

# HDO3S

ELECTRICAL ACCESS COVER  
SEE NOTE 6.0

7/16 DIA HOLES (4 PL)

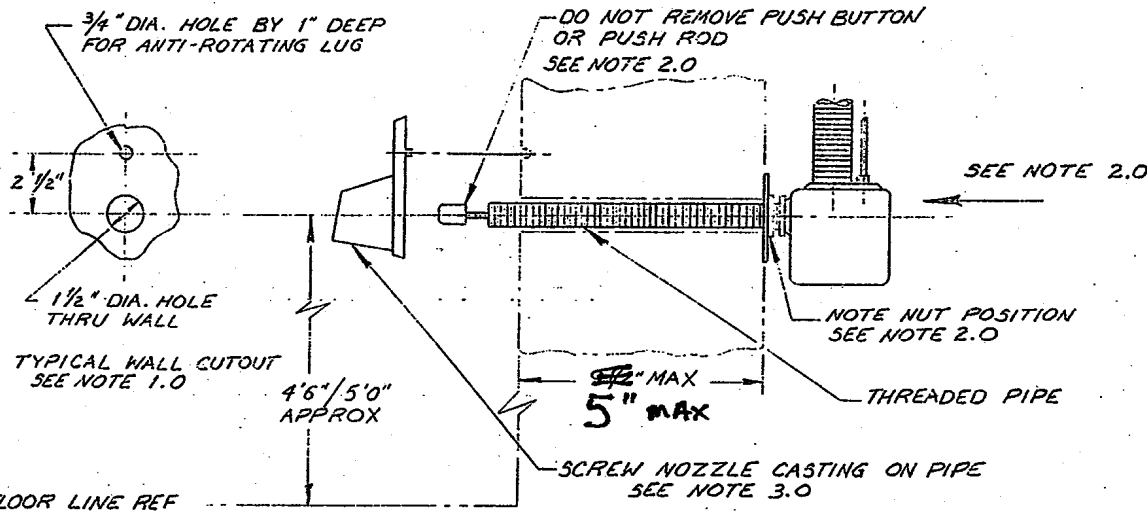
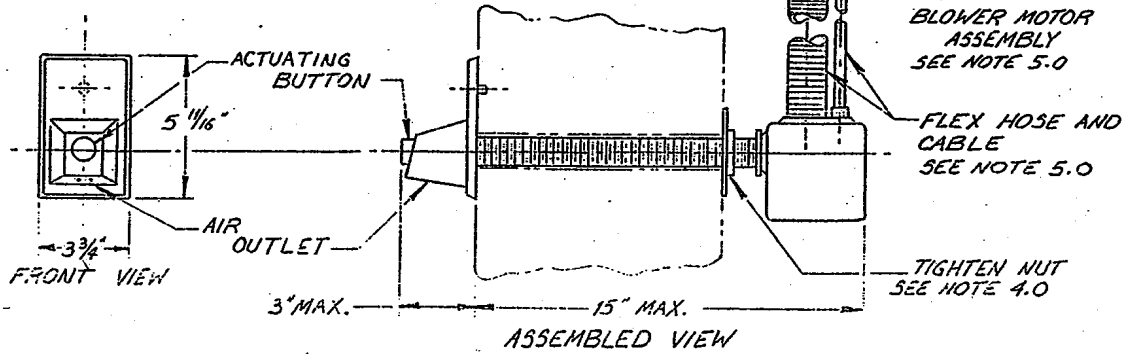

WIRING DIAGRAM  
SEE NOTE 6.0

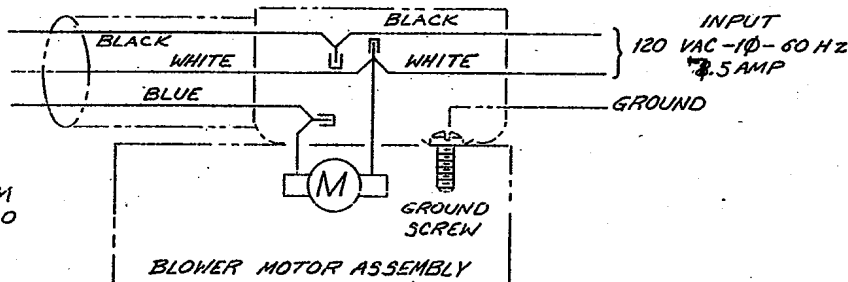

NOTES:

- 1.0 PROVIDE 1-1/2" DIA. HOLE THRU WALL APPROXIMATELY 4-1/2' - 5' ABOVE FLOOR FOR THREADED PIPE. CENTERED 2-1/2" ABOVE THIS HOLE, PUT A 3/4" HOLE APPROXIMATELY 1" DEEP FOR ANTI-ROTATING LUG.
- 2.0 BACK RETAINING NUT UP AS FAR AS POSSIBLE AND INSERT THREADED PIPE, HOUSING AND PUSH ROD ASSEMBLY THRU 1-1/2" DIA. HOLE. DO NOT ATTEMPT TO REMOVE PUSH BUTTON OR PUSH ROD.
- 3.0 SCREW NOZZLE CASING ON PIPE UNTIL DEPRESSED PUSH BUTTON IS APPROXIMATELY FLUSH WITH FRONT OF CASTING.  
CAUTION: GUIDE THE BUTTON AND PUSH ROD ASSEMBLY THRU NOZZLE CASTING WHILE TIGHTENING CASTING ON THREADED PIPE.
- 4.0 TIGHTEN RETAINING NUT TO SECURE NOZZLE CASTING TO WALL. BE SURE ANTI-ROTATION LUG IS ALIGNED WITH 3/4" DIA. RELIEF HOLE IN WALL.
- 5.0 SECURE BLOWER MOTOR ASSEMBLY WITH APPROPRIATE HARDWARE. BLOWER MOTOR MAY BE MOUNTED VERTICAL, HORIZONTAL, OR INVERTED AT ANY CONVENIENT LOCATION WITHIN THE RADIUS OF HOSE AND CABLE STANDARD LENGTH OF 3 FEET. LENGTHS OF 6 FEET AND 12 FEET MAY BE SPECIFIED. MOUNTING HARDWARE FOR BLOWER MOTOR ASSEMBLY NOT SUPPLIED WITH UNIT.
- 6.0 BEHIND ELECTRICAL ACCESS COVER IS BLACK AND WHITE WIRES. CONNECT WIRES TO 120 VOLT SUPPLY AS SHOWN IN WIRING DIAGRAM. GROUND SCREW IS PROVIDED IN OUTLET BOX ON BLOWER MOTOR ASSEMBLY.
- 7.0 UNIT CAN BE SUPPLIED WITH 220V, 1 PHASE, 60 HZ MOTOR. REQUEST QUOTE FOR THIS OPTION.

SPECIFICATIONS:

- 1.0 NOZZLE \_\_\_\_\_ CAST ALUMINUM, SANDBLAST FINISH AND CLEAR SEALANT.
- 2.0 MOTOR \_\_\_\_\_ UNIVERSAL TYPE; 1/6 HP WITH LUBRICANT BALL BEARINGS 2-STAGE BLOWER AND FILTER.
- 3.0 TIMER \_\_\_\_\_ 30 SECOND TIME TO SHUT OFF AFTER START.
- 4.0 AIR FLOW \_\_\_\_\_ 50 CFM, APPROX
- 5.0 POWER \_\_\_\_\_ 120 VOLTS, 1 Ø, 60 HZ, 7.5 AMP AC. NO ELECTRIC HEATING COILS
- 6.0 WEIGHT \_\_\_\_\_ 17 LBS.

CONTROLLED  
DRAWING

REVISONS (SEE DCN)	CHG CL	BY	DATE
D	1/16	9/22	9/22
	2	PAB	9/20/71
	3		
	4		
	5		

FASTAIRE  
P.O. Box 9956  
San Diego CA 92169  
Phone or FAX (619) 454-3548

TITLE: OUTLINE DRAWING  
THRU THE WALL MOUNTED  
FASTAIRE  
HAND DRYER

DRAWN BY: BRUGLER  
CHECKED BY: [Signature]  
DESIGN ENG: [Signature]

DATE: 9/24/71  
DATE: [Signature]  
DATE: [Signature]

PROJ ENG: [Signature]  
DATE: [Signature]  
DATE: [Signature]

CUSTOMER REF MATL

UNLESS OTHERWISE SPECIFIED  
LIMITS ON DIMENSIONS ARE  
DECIMAL .XX = ± .03  
XXX = ± .010  
ANGULAR = ± 1/2°

SCALE: 1/4  
DWG: C  
MODEL NO.: HD-03  
REV: D  
LTR